

ADDAC System

ADDAC605 VC SPECTRAL TILT
USER'S GUIDE . REV01

August.2020

Welcome to:

ADDAC605 VC SPECTRAL TILT USER'S GUIDE

Revision.01 August.2020

OVERALL FEATURES

The TILT EQ concept was first introduced in the 1970's by Quad Ltd, featured on the company's model 34 preamplifier. The tilt control tilts the frequency spectrum of the audio signal by simultaneously boosting the treble and cutting the bass frequencies, or vice versa, making it a simple to use but powerful EQ.

As stated by Quad Ltd, it was designed to produce a very gradual change in balance across the musical spectrum without changing the overall subjective level. This gradual fall from Bass to Treble, or vice versa, means there's no sudden change and hence no 'coloration' added to the sound, the sound will remain entirely natural but with a slight added bottom or high end.

In practice, it rotates most of the audio-range frequency response around a 1Khz axis, so as to change the overall balance of the sound from warm to cool without affecting either the apparent volume or the "color" of the sound.

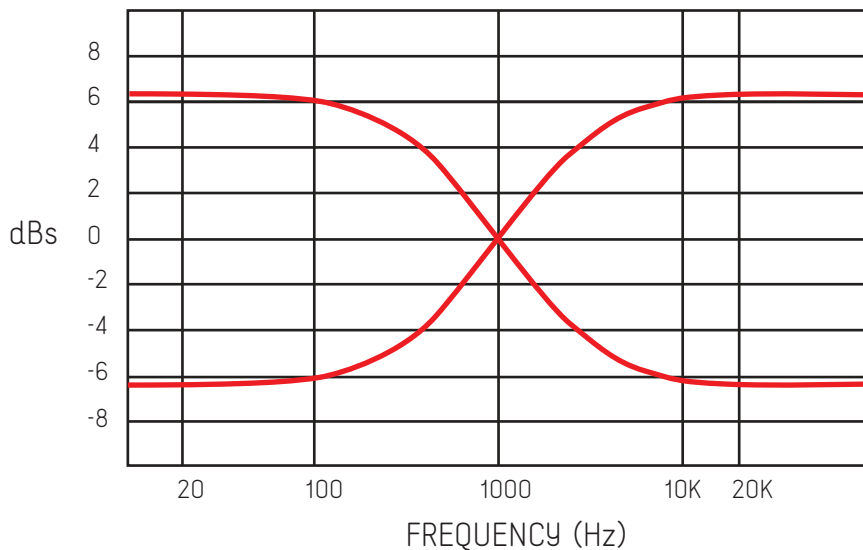

Here we introduce this idea into the modular world in a stereo configuration. CV input with attenuverter was added for the Tilt control as well as a Spectral Motion switch that allows stereo

spectral matching or inverted spectrum use of the Tilt control:

Left-Right matches both channels direction, i.e. when left channel is tilted to the low end the right channel will also be tilted to the low end

Left ≠ Right inverts the Right channel spectrum, i.e. when left channel is tilted to the low end the right channel will be inversely tilted to the high end, or vice-versa. This possibility is extremely interesting when applied as a stereo effect, in other words a spectral EQ panner.

CONTROLS DESCRIPTION

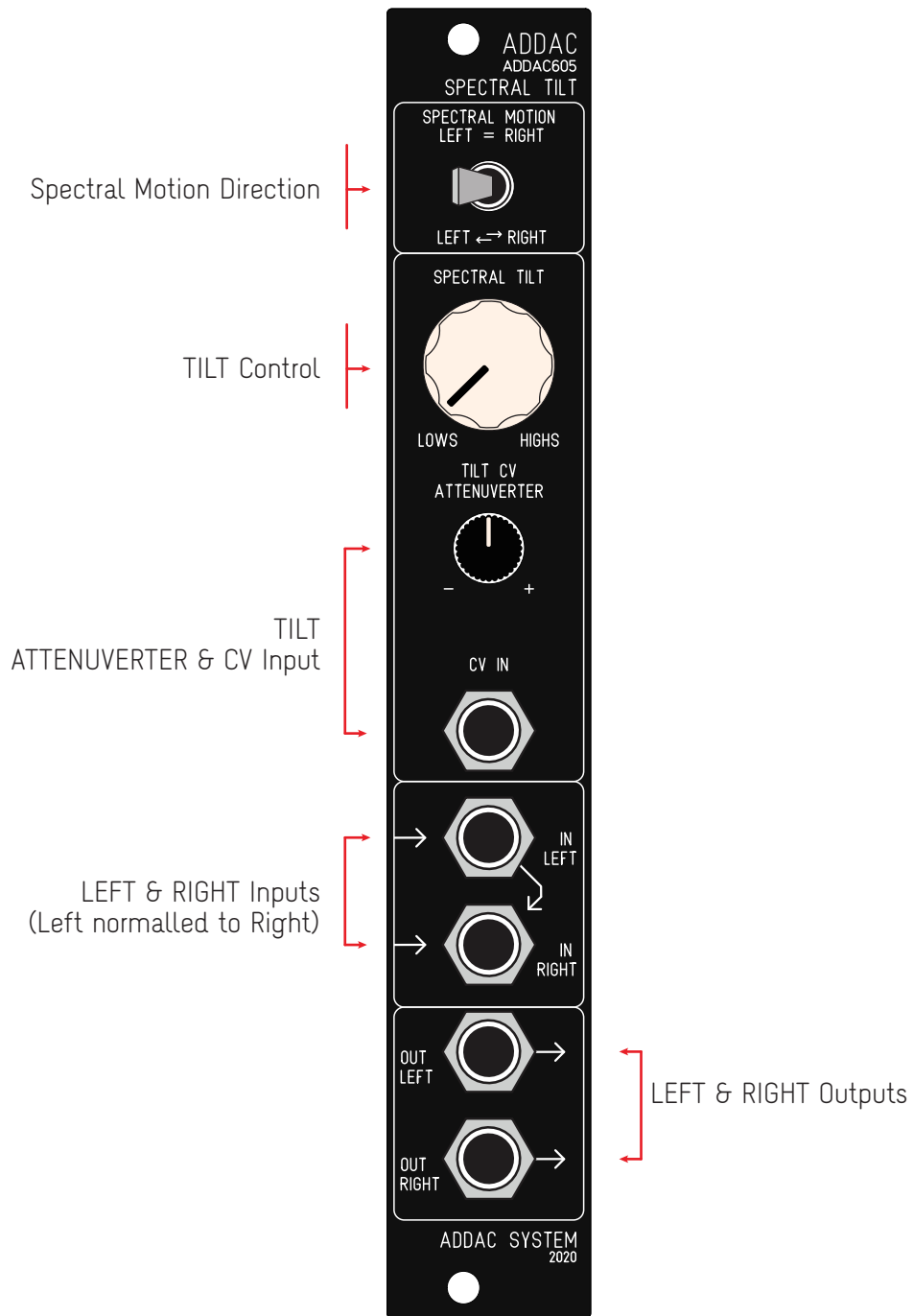

ADDAC605

VC SPECTRAL TILT

SIGNAL FLOW DIAGRAM

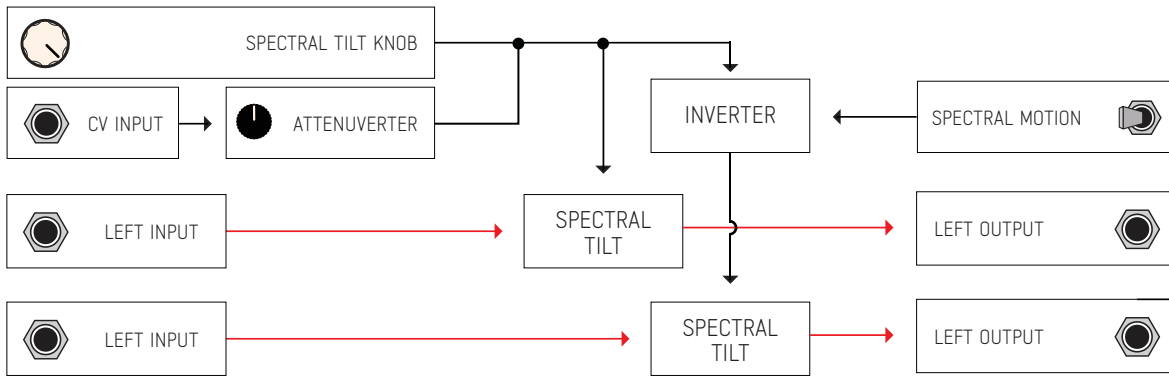

For feedback, comments or problems please contact us at:
addac@addacsystem.com